

## Multimedia Information Coding and Description Lab experience n. 9

### Sub-band filtering

Consider the filter bank with the following perfect reconstruction Haar analysis and synthesis filters

$$h_L = \left[ \frac{\sqrt{2}}{2} \quad \frac{\sqrt{2}}{2} \right] \quad h_H = \left[ \frac{\sqrt{2}}{2} \quad -\frac{\sqrt{2}}{2} \right] \quad g_L = \left[ \frac{\sqrt{2}}{2} \quad \frac{\sqrt{2}}{2} \right] \quad g_H = \left[ -\frac{\sqrt{2}}{2} \quad \frac{\sqrt{2}}{2} \right] \quad (1)$$

Consider then the separable application of these filter bank to an image according to the following scheme for horizontal and vertical filtering and sub-sampling

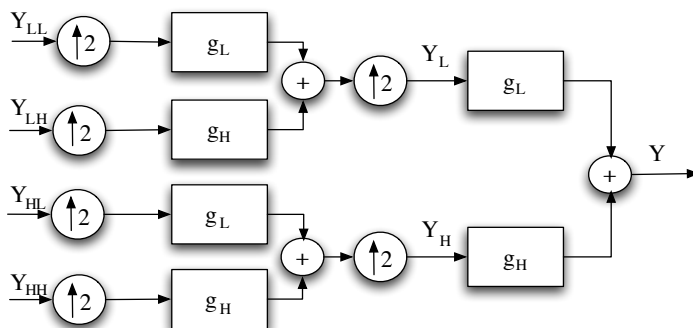
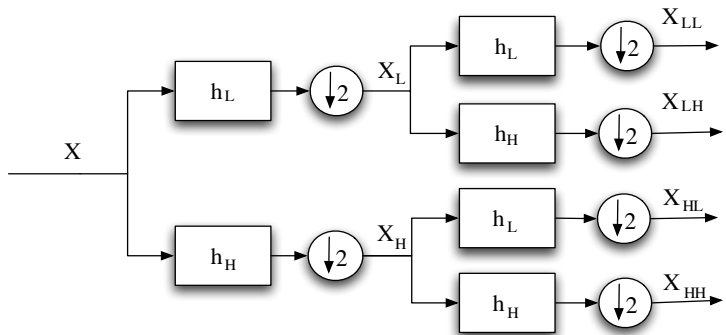

1. Implement the analysis bank by filtering the signal  $X$  first by columns, so obtaining  $X_L$  and  $X_H$ , and then filtering by rows those two signals to obtain  $X_{LL}$ ,  $X_{LH}$ ,  $X_{HL}$ ,  $X_{HH}$ .
2. Display the four sub-bands  $X_{LL}$ ,  $X_{LH}$ ,  $X_{HL}$ ,  $X_{HH}$  and observe the different content of each sub-band.
3. Implement the synthesis bank and check that the filter bank is perfect-reconstruction.
4. Evaluate the quality of the image obtained by only using the LL sub-band in the synthesis phase (quantize the remaining sub-bands to zero).
5. Iterate the sub-band analysis and synthesis process on the LL sub-band, and repeat the experiment of the previous two points.

Bonus: Apply a uniform (non-zero) quantization to different sub-bands and study its effect on the quality of the reconstructed image.